

FIT[®] 120H

Heat Recovery Ventilator



STANDARD FEATURES

- Premium aluminum cell
- Fans with backward curved blades
- Cabinet height of 10 1/4 (260 mm)

OPTIONAL CONTROLS

- Compatible with Fantech's ECO-Touch, EDF7, EDF1, RTS5, RTS2 and MDEH1.



Job Name:		
Job Location:		
Job Reference Number:		
Unit Reference Number:		
Engineer:		
Distributor:		
Contractor:		
For Reference:	For Approval:	For Construction:
Submitted by:	Date:	
Address:		
Tel:	Fax:	Email:
Notes:		

United States 10048 Industrial Blvd. • Lenexa, KS 66215 • 1.800.747.1762 • www.fantech.net
Canada 50 Kanalfakt Way • Bouctouche, NB E4S 3M5 • 1.800.565.3548 • www.fantech.net

Fantech reserves the right to make technical changes.
For updated documentation please refer to www.fantech.net

Descriptions

Cabinet:	24 gauge G90 galvanized steel, insulated with 1 in. (25 mm) of foil-faced high density polystyrene foam and 0.25 in. (6 mm) of closed-cell foam on the top of the unit.
Fans:	Two (2) factory-balanced fans with backward curved blades. Motors come with permanently lubricated, sealed ball-bearings to guarantee long life and maintenance-free operation.
Heat recovery core:	The heat recovery core is a fixed plate cross-flow heat exchanger using 1100 alloy aluminum and capable of transferring sensible heat between air streams. The heat recovery core is engineered with a turbulence inducing geometry in order to maximize heat transfer while allowing an effective evacuation of condensate. The plates are hemmed to avoid cross-contamination of airstreams.
Filters:	The filters are washable electrostatic panel type air filters. Exhaust air filter dimensions 11.2" (284mm) x 7" (176 mm) x 0.125" (3mm). Supply air filter dimensions 11.4" (289mm) x 7.7" (196 mm) x 0.125" (3mm).
Optional controls:	Compatible with Fantech's ECO-Touch, EDF7, EDF1, RTS, RTS2 and MDEH1.
Frost control:	A preset frost control sequence shall be activated at an outdoor air temperature of 23°F (-5°C) and lower. During the defrost sequence, the supply fan shuts down and the exhaust fan switches into high speed to maximize the effectiveness of the defrost strategy. The unit then returns to normal operations, and continues the cycle.
Serviceability:	Core, filters, fans and electrical panel can be accessed easily from the access panel. Core conveniently slides out with only 8" (203 mm) clearance.
Mounting:	Unit is to be suspended by using ceiling bracket, supplied.
Warranty:	The heat recovery aluminum core has a Limited Lifetime Warranty. Unit shall have a warranty that is limited to 5 years on all parts and 7 years on fans from the date of purchase, including parts replaced during this time period. If there is no proof of purchase available, the date associated with the serial number will be used for the beginning of the warranty period.

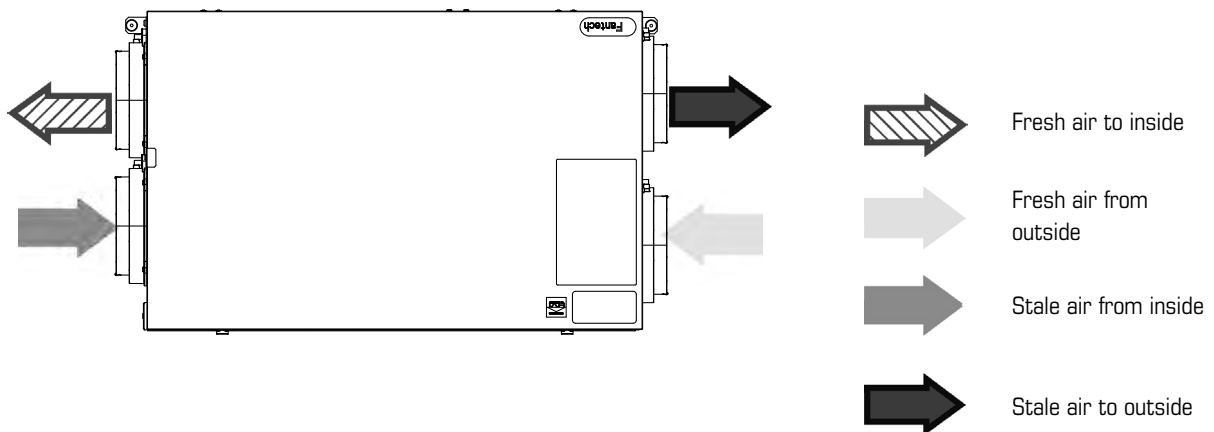

Specifications

- Volts: 120V
- Phase: Single
- Amperage: 1.4 Amps Total
- Blowers (x2): 120V, 60Hz, 65W

- Weight: 42 Lbs (19 Kg)
- Shipping Weight: 50 Lbs (23 Kg)
- Shipping Dim.: 35.5" x 23.5" x 12" (902 x 597 x 305 mm)

Ventilation Performance

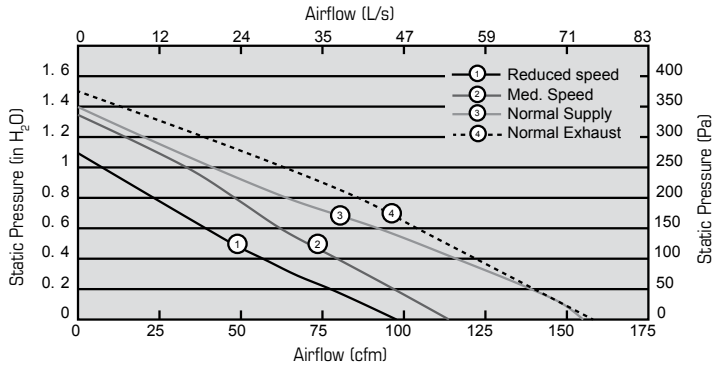

Energy performance

Heating	Supply temperature		Net airflow		Consumed power	Sensible recovery efficiency	Apparent sensible effectiveness	Latent recovery/moisture transfer
	°F	°C	cfm	L/s	W	%	%	-
	32	0	60	28	66	65	77	0.00
	32	0	86	41	96	64	76	0.01
	32	0	117	55	148	60	71	0.01
	-13	-25	65	31	63	56	81	0.00

Dimensions

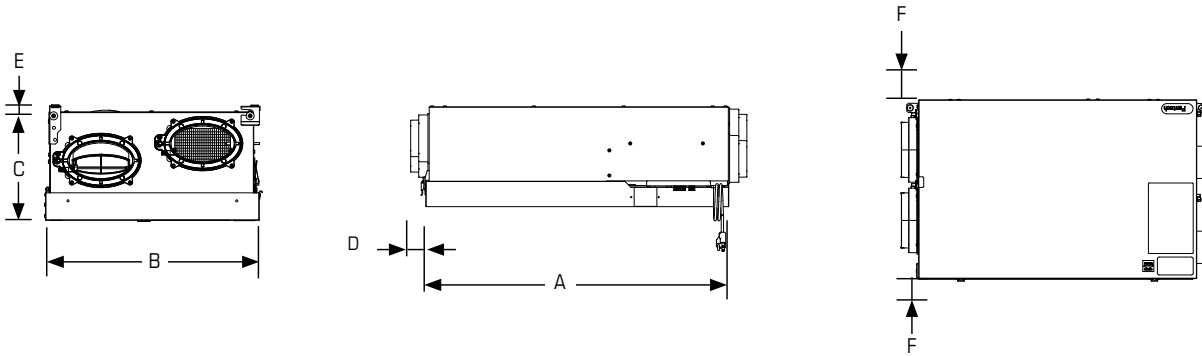

Model	A		B		C		D		E		F*	
	in	mm	in	mm	in	mm	in	mm	in	mm	in	mm
FIT 120H	31	785	20 1/4	515	10 1/4	260	1 7/8	50	1/2	14	3	75

* clearance required to open door.

United States 10048 Industrial Blvd. • Lenexa, KS 66215 • 1.800.747.1762 • www.fantech.net

Canada 50 Kanalfakt Way • Bouctouche, NB E4S 3M5 • 1.800.565.3548 • www.fantech.net

Fantech reserves the right to make technical changes.
For updated documentation please refer to www.fantech.net